

EXPLORER SHRIMP-EX-STD

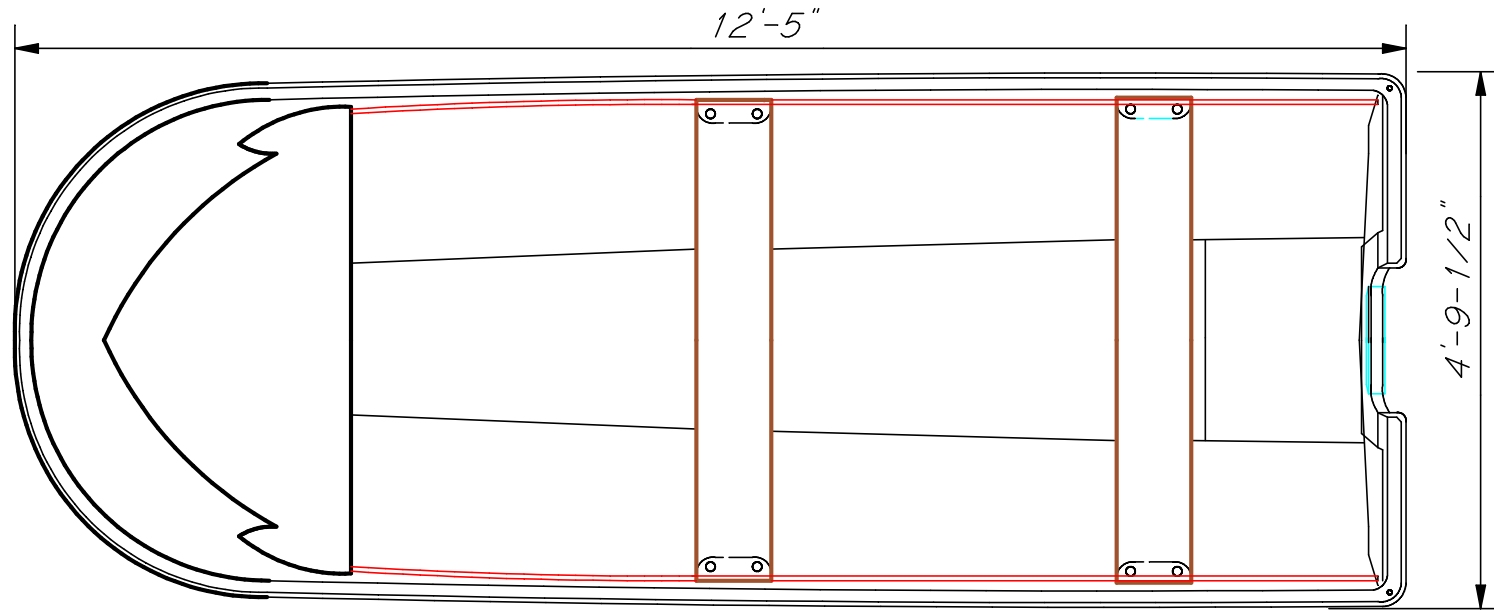

MAIN DECK PLAN

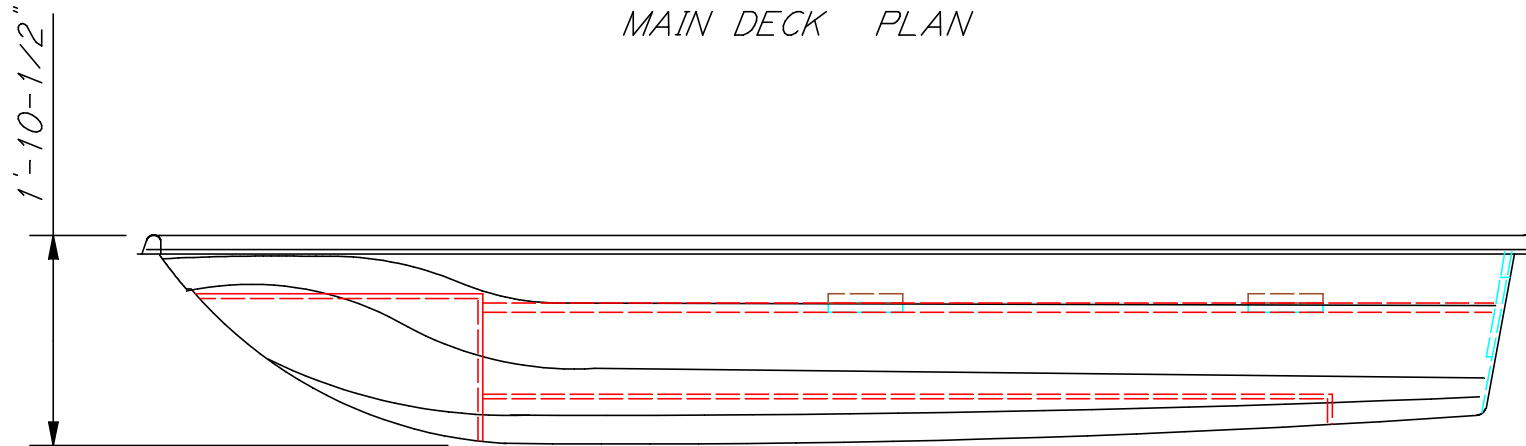

INBOARD PROFILE

EXPLORER COMPOSITE SDN. BHD.
1320-C, BT.4-1/2, KLEBANG BESAR, 75200 MELAKA, MALAYSIA
TITLE : GENERAL ARRANGMENT
TYPE OF BOAT : GT TOPPER-STD
DRAWING NO : L - 02 - 005
SCALE : 1:25
DATE :05/02/2023

OVERALL LENGTH (LOA) : 12FT- 5"IN (3.78M)
LENGTH WATER LINE (LWL) : ~10FT-7"IN (3.23M)
BREADTH MOLDED (B) : 4-FT 9.5"IN (1.46M)
DEPTH MOLDED (D) : 1FT 10.5"IN (0.57M)
DRAFT DESIGNED (T) : ~6"-IN (0.15M)
TRANSOM HEIGHT : 1FT 3"IN (0.38M)

HULL MATERIAL : FIBERGLASS
APPLICATION REQUIREMENT : FISHING BOAT
DRY WEIGHT (W) : ~50KG
RATED POWER : ~1X15HP-OBM
LOADING CAPACITY : ~4-PERSONS
FUEL TANK CAPACITY : -