

EXPLORER GRANDE EX 13.5 STD MODEL

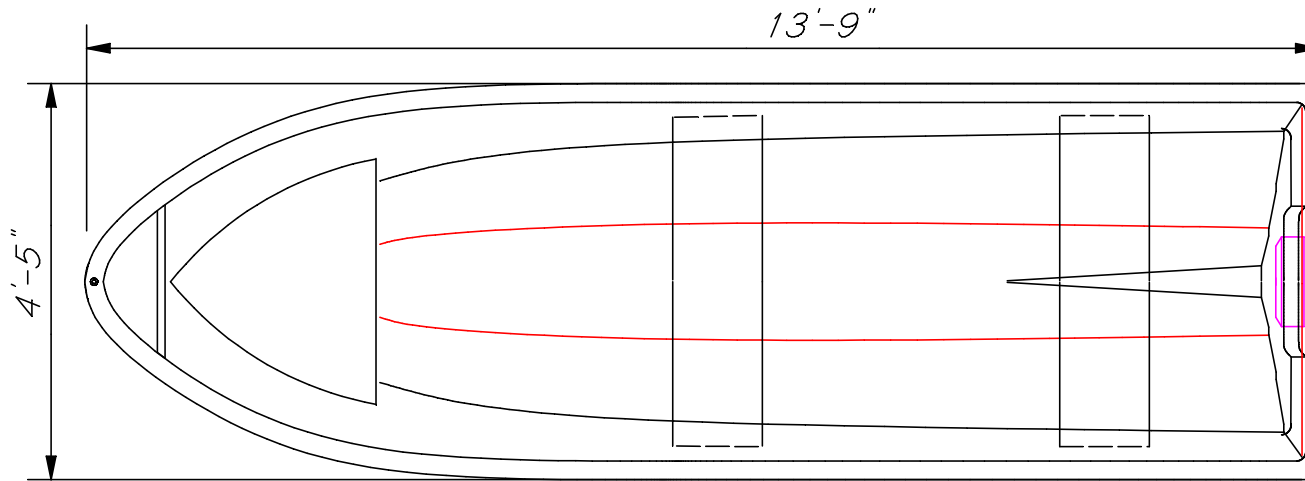

PLAN VIEW

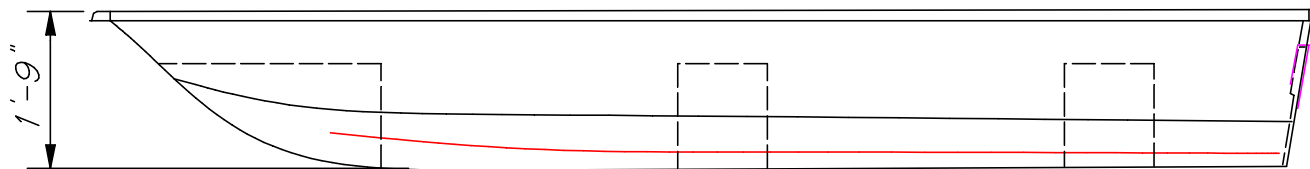

INBOARD PROFILE

EXPLORER COMPOSITE SDN. BHD.
1320-C, BT.4-1/2, KLEBANG BESAR, 75200 MELAKA, MALAYSIA
TITLE : GENERAL ARRANGMENT
TYPE OF BOAT : GRANDE GRT EX-13.5 STD
DRAWING NO : L - 02 - 006
SCALE : 1:25
DATE : 05 / 02 / 2023

OVERALL LENGTH (LOA) : 13FT 9IN
LENGTH WATER LINE (LWL) : ~12FT
BREADTH MOLDED (B) : 4FT 5IN
DEPTH MOLDED (D) : 1FT 9IN
DRAFT DESIGNED (T) : ~7IN
TRANSOM HEIGHT : 1FT 3IN

HULL MATERIAL : FIBERGLASS
APPLICATION REQUIREMENT : FISHING BOAT
DRY WEIGHT (W) : ~60KG
RATED POWER : ~1X15HP-OBM
LOADING CAPACITY : ~4PERSONS
FUEL TANK CAPACITY : -