

EXPLORER F240-WR

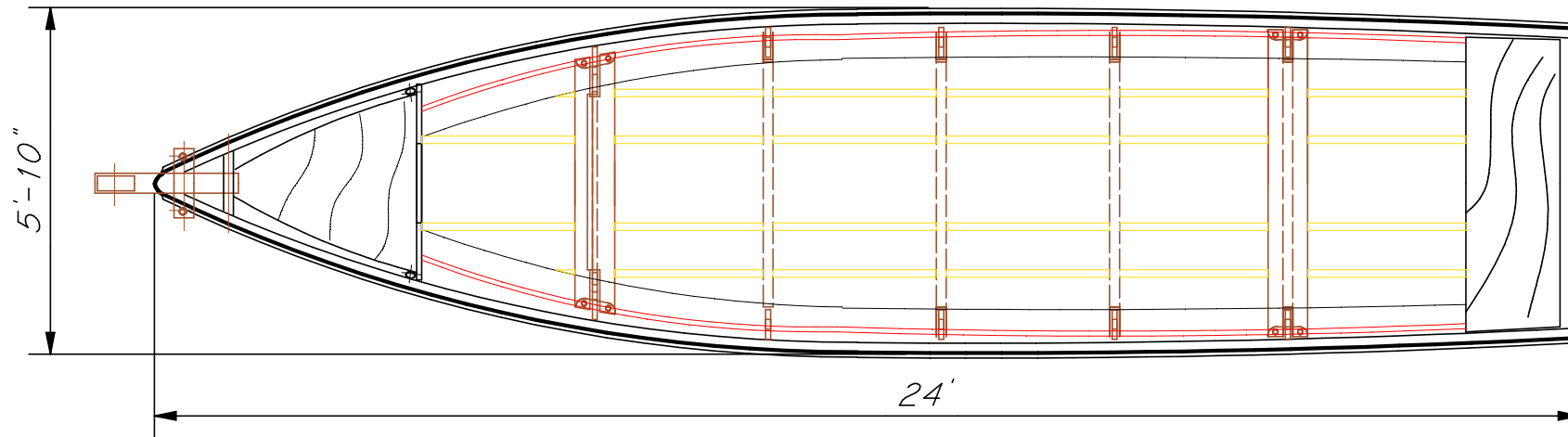

MAIN DECK PLAN

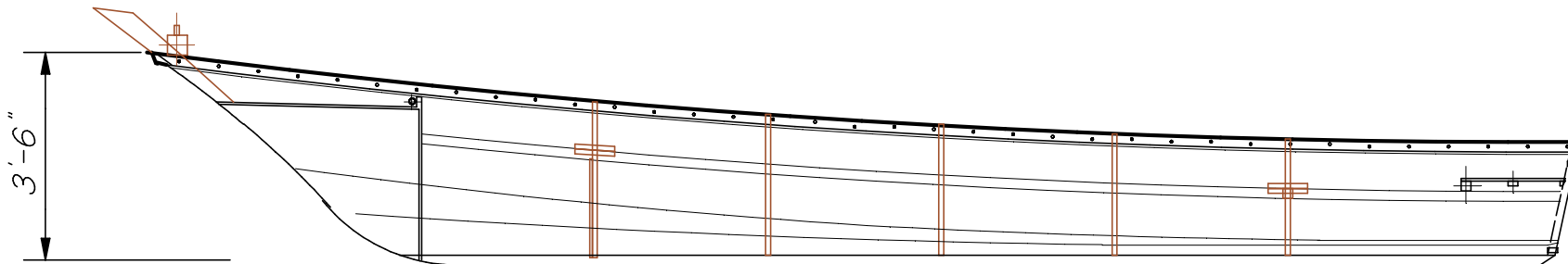

INBOARD PROFILE

EXPLORER COMPOSITE SDN.BHD
1320-C, BT.4-1/2, KLEBANG BESAR, 75200 MELAKA, MALAYSIA
TITLE : GENERAL ARRANGMENT
TYPE OF BOAT : F240-WR
DRAWING NO : L - 03 - 014
SCALE :
DATE : 05 / 02 / 2023

OVERALL LENGTH HULL (LOA) : 24FT (7.39M)
LENGTH WATER LINE (LWL) : ~20FT. 6IN.(6.29M)
BREADTH MOLDED (B) : 5FT. 10IN (1.78M).
DEPTH MOLDED (D) : 3FT. 6IN (1.07M).
DRAFT (T) : ~ 6FT (0.15M).
TRANSOM HEIGHT : 1FT. 8IN (0.51).

HULL MATERIAL : FIBERGLASS
APPLICATION REQUIREMENT : FISHING BOAT
DRY WEIGHT(W) : ~350KG
RECOMMENDED POWER : 1 x 60HP OBM
LOADING CAPACITY : ~8PERSONS
FUEL TANK CAPACITY : -