

EXPLORER 320 OD SEA QUEST

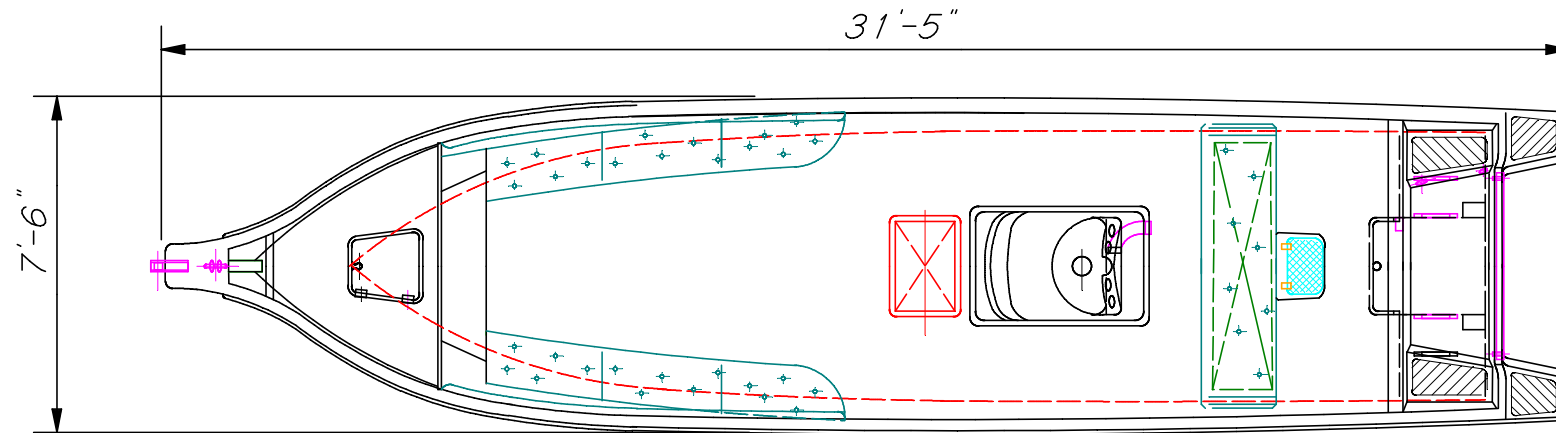

MAIN DECK PLAN

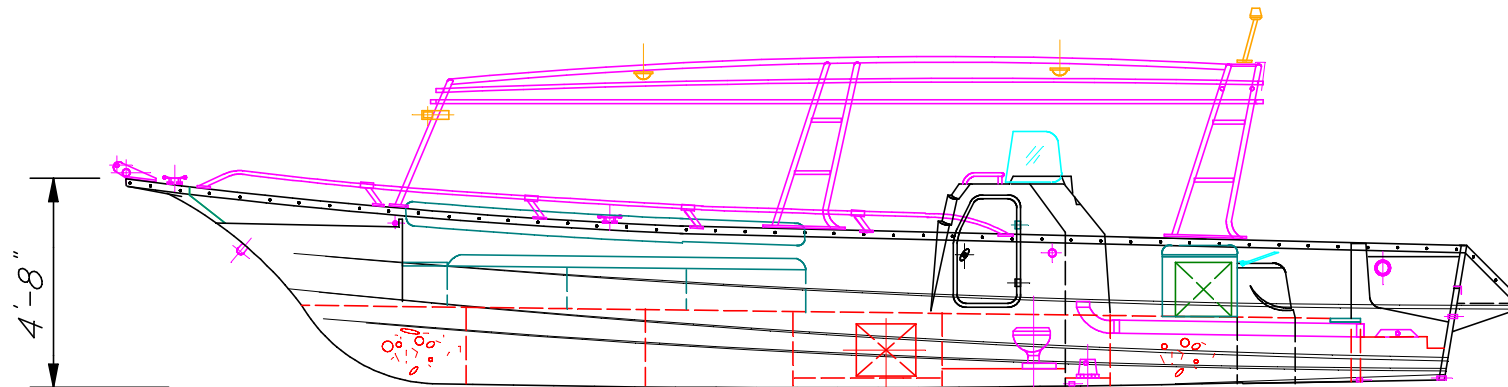

INBOARD PROFILE

EXPLORER COMPOSITE SDN. BHD.
 1320-C, KLEBANG BESAR, 75000 MELAKA, MALAYSIA
 TITLE : GENERAL ARRANGEMENT
 TYPE OF BOAT : EXPLORER 320-OD-SEA QUEST
 DRAWING NO : E320_E122
 UNIT TYPE : FEET/INCHES
 SCALE : 1 : 50
 DATE : 05-02-2023

OVERALL LENGTH(LOA) : 31FT 5IN
 LENGTH WATER LINE(LWL) : ~25FT 6IN
 BREADTH MOLDED(B) : 7FT 6IN
 DEPTH MOLDED(D) : 4FT 8IN
 DRAFT DESIGNED(T) : ~1FT 4IN@FP, 1FT 2IN@AP
 TRANSOM HEIGHT : 2FT 11IN

HULL MATERIAL : FIBERGLASS
 APPLICATION REQUIREMENT : SPORT FISHING
 DRY WEIGHT(W) : ~960KG
 RATED POWER : 2 x 150HP @ 1 x 300 HP
 SEATING CAPACITY : ~12PERSONS
 FUEL TANK CAPACITY : ~50GALLONS
 WATER TANK CAPACITY : ~15GALLONS